

2019 SkillsUSA GA State Championships Contest Update for Post-Secondary Contestants

Welding

Updated Details

February 28, 2019

Welcome to the Georgia Skills USA Competition. By appearing at this contest, you have prepared yourself to compete with other welding students in the following practical skills areas: Oxy-Fuel Cutting, Shielded Metal Arc Welding, Flux Core Arc Welding, Gas Tungsten Arc Welding, and Gas Metal Arc Welding. In addition to these practical skills, you are saying you have prepared yourself academically in the areas of welding fundamentals, welding math, geometrical layout, and blueprint reading and welding symbols. This contest has been designed to test your abilities in each of those areas and to select the best welder to represent the State of Georgia.

Contest Schedule

Written testing must be done prior to attending contest

Friday, March 22, 2019	12:30pm – 12:45pm	Report to contest location in main hall for Roll Call
	12:45pm – 3:30pm	Complete Welding project

What Happens After Roll Call

Once everyone has been identified, you will only be known by your number assigned from GA Skills USA. Place your number on the back of your welding jacket and keep that number visible for the judges. Once you have successfully been assigned a number, you will be escorted to the contest area for further briefing and a welding apparel safety inspection from the process supervisor.

Any contestants not wearing appropriate welding clothing, including work boots, and other safety equipment, will not be allowed to compete and will be *removed* from the contest at this point. Any questions about the contest should be asked during this time.

After arrival to your work area and subsequent apparel safety inspection the contestants can get prepared for the contest start. During this time, it would be a good time to put on your personal protection gear needed for the contest.

Once the Contest Begins

The welding contest is time limited to three hours. You will be given raw iron and be required to complete the project out of the provided material per the drawing provided to you.

- Contestants will be given 10 minutes at the beginning of the contest to use electric grinders for the purpose of cleaning Mill Scale off plates. Judges will inspect plates after allotted grinding time and sign off on work. Electric Grinders will not be used after this allotted time.
- Once assembled Project can be rotated horizontally but **not vertically**. All welds must be done in the position called for on the print.

At the end of the contest period, the students will be instructed to stop immediately, pack up all tools & equipment, and clean-up work area.

Do's and Don'ts

- DO relax and have some fun.
- DO notify a contest area judge or contest volunteer you need to leave to use the rest room and follow the do not's below and make it quick.
- DO NOT plan to use 'shared' tools from another competitor.
- DO NOT 'Give up' and walk away from the contest without consulting the contest chairman.
- DO NOT talk to anyone outside the contest area.
- DO NOT talk to your weld advisor.
- DO NOT talk to fellow welding competitors from the same school or town.
- DO NOT Enter the work area or begin work until notified by judges.

What to do if you have a problem

IMMEDIATELY alert one of the process monitors so that we can troubleshoot your problem if there is a problem with the equipment or the parts or something that has to do with the materials and equipment provided by the contest committee.

If there is a problem with the items we provided, the competitor will be allowed make up time. No make-up time will be allowed if the student stops and asks for help with contest specifics such as drawing details or weld symbol interpretation or basic welding knowledge that is being tested, including machine set up and weld settings.

Supplied by the contestant team:

- 1- 4 ½" grinder (must be in good working order with guards and safety features enabled)
- Compass
- Tape measure
- Soap stone with holder
- Scribe with magnet
- Friction Lighter (striker)
- 11r or 10-inch vise grips
- 16-ounce ball peen hammer
- Center Punch
- Chipping hammer
- Mig pliers
- Combination square set
- Wire brush
- Fillet weld gauge
- Pocket calculator
- Lead pencil and/or ballpoint pen

Required Safety:

- Hearing and/or ear protection
- Welding Hoods with appropriate filter plate/lens and protective cover plate/lens in a flip or slide front. Auto darkening shields are permissible
- Spare spatter and filter lenses/plates for arc welding hood and oxyacetylene goggles
- Personal Protection Equipment
 - Safety Glasses
 - Welding Gloves
 - Welding jacket or sleeves
 - Leather Boots (preferably steel toe)
 - Work pants without holes or frays
- Cutting Glasses or Goggles (Shade 3 to 5)

Please be aware that we will be using Propane/Oxygen combination for torch cutting operations with Harris products. (0 Tip Size) Representatives will be on site to help with equipment setup and questions

SkillsUSA Contest will provide

- Drawings with weld details and cutting directions
- Necessary Steel materials to complete project
- Welding and Torch Cutting Equipment
- Miller Fabrication table in booth
- Welding Booth

Good Luck

Once again congratulations on reaching this competition and please understand that it is our goal to operate an honest, fair, and rewarding contest. All involved in managing this contest strive to make it happen to reward excellence among the future welding workforce of Georgia. Good luck to all in the contest and also in your welding careers.

Respectfully,

Chris Tobiasson

Technical Chair Welding Competition

See attached drawings

WELDING PROCEDURES

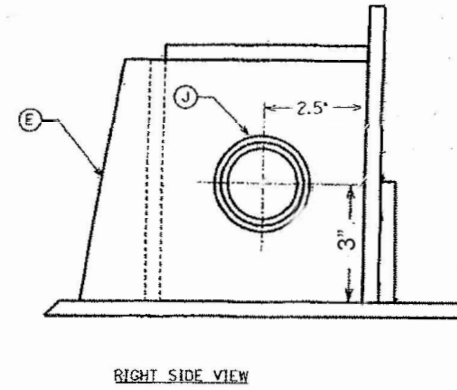
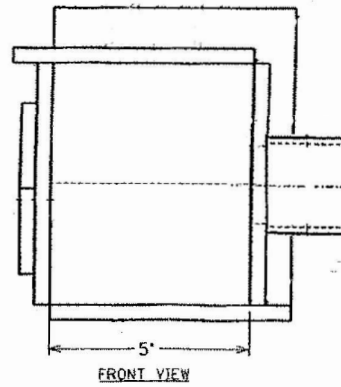
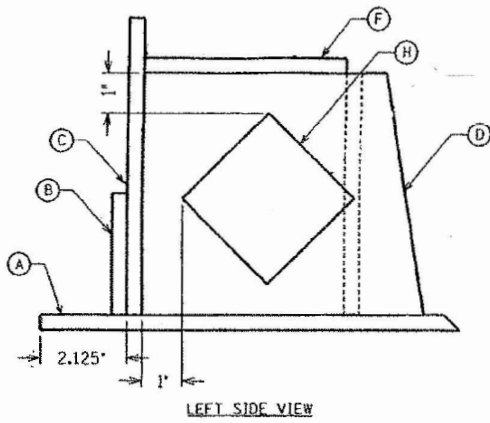
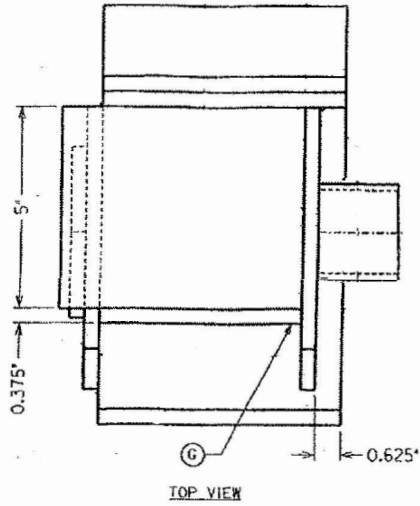

PART NO.	Qty.	DESCRIPTION
J		2 x 2 SCHEDULE 40 PIPE
H		3 x 3 x 3/8 STL PLATE
C		6 x 5 x 3/8 STL PLATE
F		6 x 5 x 3/8 STL PLATE
E		6 x 7 x 3/8 STL PLATE
D		6 x 7 x 3/8 STL PLATE
G		6 x 7 x 3/8 STL PLATE
B		6 x 3 x 3/8 STL PLATE
A		6 x 11 x 3/8 STL PLATE

BILL OF MATERIAL

MACH STATE SKILLS U.S.A. ASSEMBLY

DRAWN	B. WILLIAMS	DATE	1-22-88	SCALE	
CHK'D	RJK.				
PRG'D	R.L.C.				

SW-2012-008 A