

WELDING PROCEDURES			
WELD	PROCESS	POSITION	SPECIAL INSTRUCTIONS

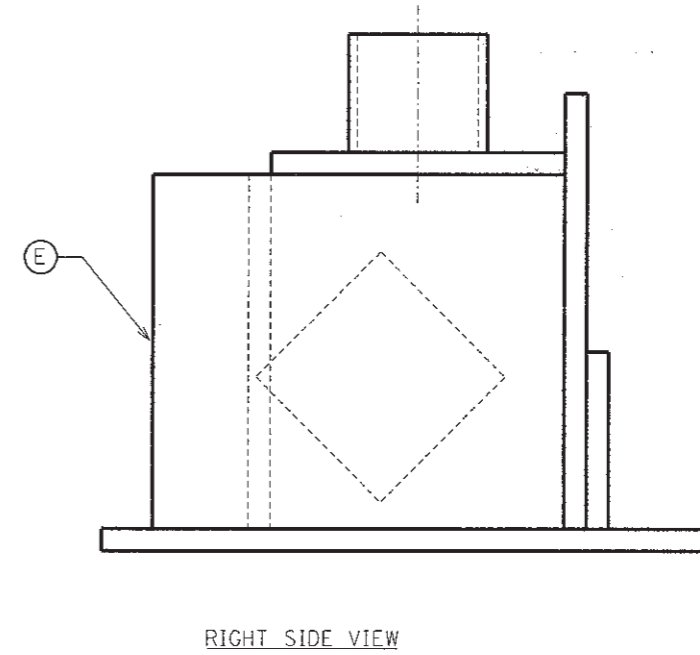
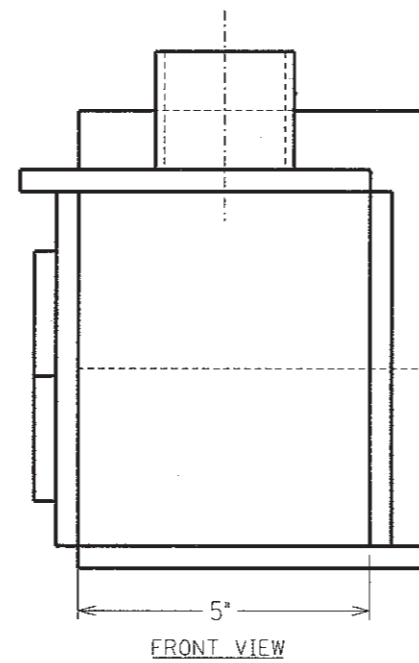
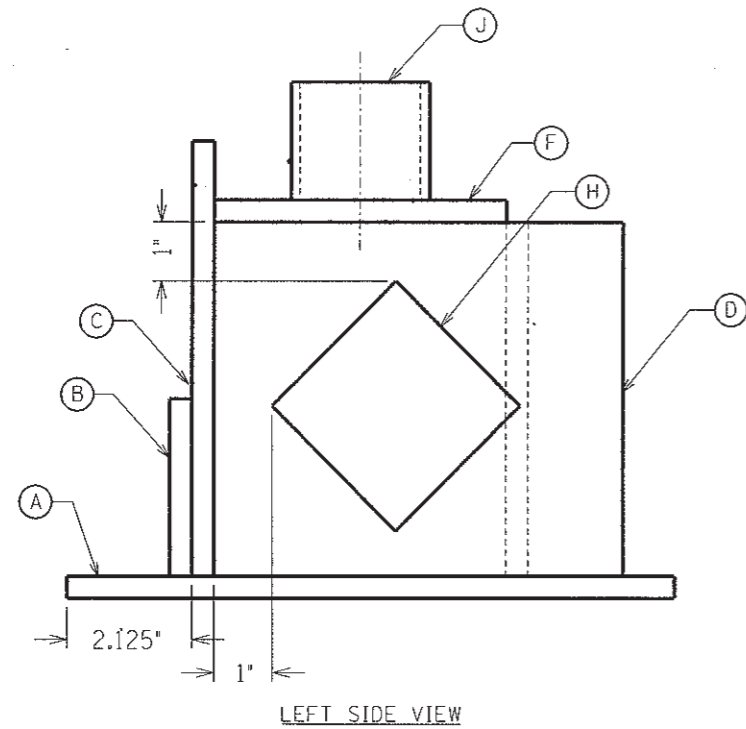
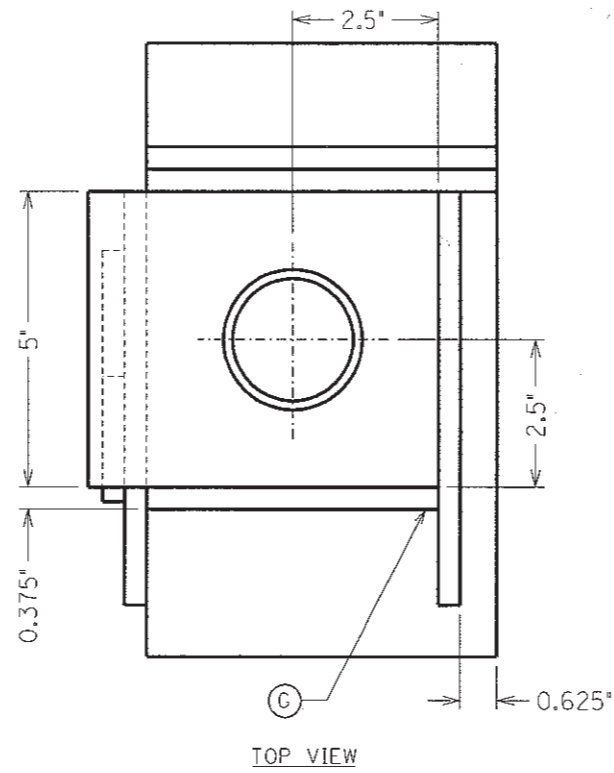

PART NO.	Qty.	DESCRIPTION
J	1	2" x 2" SCHEDULE 40 PIPE
H	1	3" x 3" x 3/8" STL PLATE
G	1	6" x 5" x 3/8" STL PLATE
F	1	6" x 5" x 3/8" STL PLATE
E	1	6" x 7" x 3/8" STL PLATE
D	1	6" x 7" x 3/8" STL PLATE
C	1	6" x 7" x 3/8" STL PLATE
B	1	6" x 3" x 3/8" STL PLATE
A	1	6" x 11" x 3/8" STL PLATE

BILL OF MATERIAL

MACH	STATE SKILLS U.S.A.		
	ASSEMBLY		
	DRAWN	B. WILLIAMS	DATE 1-22-08
	CHK'D	O.K.	SCALE
MACH NO.	LOC.	SW- 2012-011	A